

MIP1000 KNX IP Router

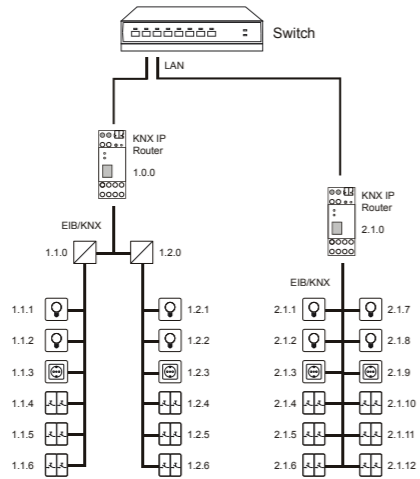

Fig. 3: KNX IP Router as a backbone and line coupler

Application

The KNX IP Router forwards telegrams between different lines via a rapid LAN (IP) backbone. The KNX IP Router can also be used as an interface for accessing the bus via IP, replacing an RS232 or USB interface. It has an external 12 V to 24 V power supply or can alternatively be powered via Power-over-Ethernet (IEEE 802.3af).

Coupler function (KNXnet/IP routing)

The IP Router can operate as a line and/or backbone coupler. In both cases, the LAN (IP) acts as a backbone.

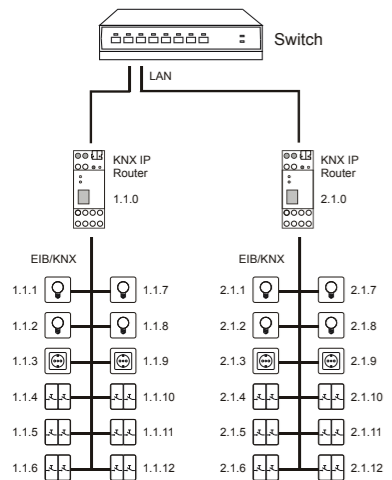

Fig. 1: KNX IP Router as a line coupler

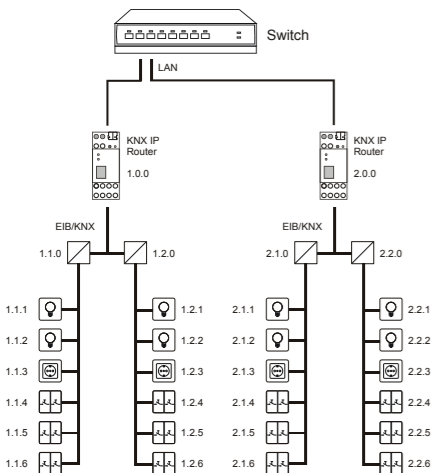

Fig. 2: KNX IP Router as a backbone coupler

The physical address assigned to the KNX IP Router determines whether the device operates as a line or backbone coupler. If the physical address is in the form of x.y.0 (x, y: 1..15), the router operates as a line coupler. If it is in the form of x.0.0 (x: 1..15), the router acts as a backbone coupler.

Attention:

If the KNX IP Router is used as a backbone coupler (x.0.0), there must be no KNX IP Router in the topology beneath it. For example, if a KNX IP Router has the physical address of 1.0.0, there must be no KNX IP Router with the address 1.1.0.

If the KNX IP Router is used as a line coupler (x.y.0), there must be no KNX IP Router in the topology above it. For example, if a KNX IP Router has the physical address of 1.1.0, there must be no KNX IP Router with the address 1.0.0.

The KNX IP Router has a filter table and thus contributes to reducing bus load. The filter table is automatically generated by the ETS.

Because of the speed difference between the Ethernet (10 Mbit/s) and KNX/EIB (9.6 kbit/s), a far greater number of telegrams can be transmitted on IP. If several consecutive telegrams are transmitted on the same line, they must be buffered in the router to avoid telegram loss. The KNX IP Router has a memory for 150 telegrams (from IP to KNX/EIB).

Bus access function (KNXnet/IP Tunneling)

The KNX IP Router can be used as an interface to KNX/EIB. KNX/EIB can be accessed from any point in the LAN. For this purpose, a second physical address must be assigned as described in the ETS Connection Manager section.

ETS database

The following parameters can be set on the ETS:

General:

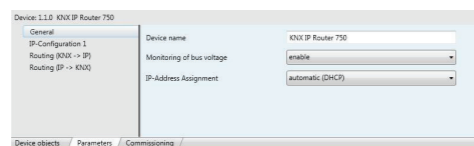

Device name:

The KNX IP Router can be assigned a name of your choice. The device name should be descriptive (e.g. Line TF). It is used to search for and recognize a device.

Monitoring bus voltage failure:

If a KNX/EIB failure is detected, it is reported on the IP. Return of the bus voltage is also reported. Parameters: *disable, enable*

IP address assignment:

Automatic (DHCP): The IP address is automatically assigned on the DHCP, i.e. additional settings are not required. To be able to use this function, there must be a DHCP server in the LAN (many DSL routers have an integrated DHCP server).

Manual: In this case, the IP address, the subnet and the gateway IP address must be entered manually.

IP configuration:

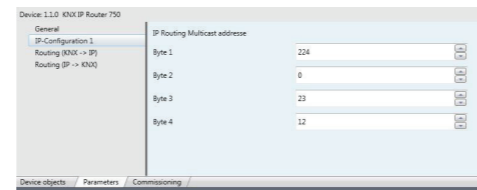

IP Routing Multicast Address:

This address is used for routing telegrams on IP. The multicast IP address 224.0.23.12 was reserved (KNXnet/IP) at the IANA (Internet Assigned Numbers Authority) for this purpose. If a different multicast IP address is required, it must lie within the range of 239.0.0.0 to 239.255.255.255.

IP address:

This is the IP address of the KNX IP Router.

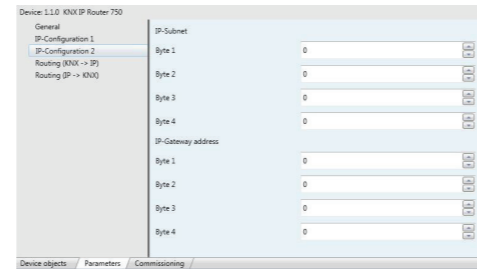

IP subnet:

Enter the subnet mask here. The device uses the values entered in this mask to determine whether there is a communications partner in the local network. If there is no partner in the local network, the device will not send the telegrams directly to the partner but to the gateway that routes the telegram.

IP gateway address:

Enter the IP address of the gateway here. Note: If the KNX IP Router will only be used in the local LAN, the entry of 0.0.0.0 can remain unchanged.

Example of assigning IP addresses:
A PC is to be used to access the KNX IP Router
IP address of the PC: 192.168.1.30
Subnet of the PC: 255.255.255.0

The KNX IP Router is located in the same local LAN, i.e. it uses the same subnet. The subnet constrains the IP addresses that can be assigned. In this example, the IP address of the IP router must be 192.168.1.xx, where xx can be a number from 1 to 254 (with the exception of 30, which is already in use). It must be ensured that no numbers are assigned twice.
IP address of the IP router: 192.168.1.31
Subnet of the IP router: 255.255.255.0

Routing (KNX -> IP)

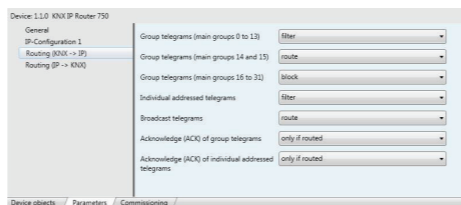

Group telegrams (main group 0 to 13):

Block: No group telegrams of this main group are routed to IP.

Route: All group telegrams of this main group are routed to IP independent of the filter table. This setting is for testing purposes only.

Filter: The filter table is used to check whether or not the received group telegram should be routed to IP.

Group telegrams (main groups 14 and 15):

Block: No group telegrams of main groups 14 and 15 are routed to IP.

Route: All group telegrams of main groups 14 and 15 are routed to IP.

Group telegrams (main groups 16 to 31):

Block: No group telegrams of these main groups are routed to IP.

Route: An additional page appears on which the routing of main groups 16 to 31 can be disabled or enabled in pairs.

Note:

The group addresses of main groups 16 to 31 are reserved addresses that can be used for special applications (e.g. in Easy Mode). These group addresses are not available in the ETS.

Physically addressed telegrams:

Block: No physically addressed telegrams are routed to IP.

Route: All physically addressed telegrams are routed to IP.

Filter: The physical address is used to check whether the received physically addressed telegram should be routed to IP.

Broadcast telegrams:

Block: No received broadcast telegrams are routed to IP.

Route: All received broadcast telegrams are routed to IP.

Acknowledge (ACK) of group telegrams:

Always: An acknowledge is generated for every received group telegram (from KNX/EIB).

Only if routed: An acknowledge is only generated for received group telegrams (from KNX/EIB) if they are routed to IP.

Acknowledge (ACK) of physically addressed telegrams:

Always: An acknowledge is generated for every received physically addressed telegram (from KNX/EIB).

Only if routed: An acknowledge is only generated for received physically addressed group telegrams (from KNX/EIB) if they are routed to IP.

Answer with NACK:

Every received physically addressed telegram (from KNX/EIB) is responded to with NACK (not acknowledge). This means that communication with physically addressed telegrams on the corresponding KNX/EIB line is not possible. Group communication (group telegrams) is not affected. This setting can be used to block attempts at manipulation.

Routing (IP -> KNX)

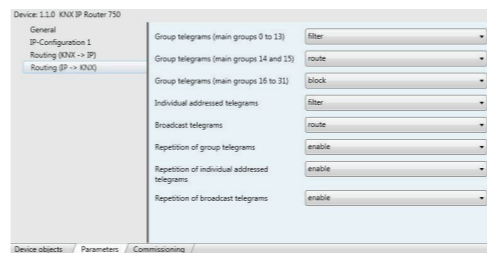

Group telegrams (main groups 0 to 13):

Block: No group telegrams of these main groups are routed to KNX/EIB.

Route: All group telegrams of this main group are routed to KNX/EIB independent of the filter table. This setting is used for testing purposes only.

Filter: The filter table is used to check whether the received group telegram should be routed to KNX/EIB.

Group telegrams (main groups 14 and 15):

Block: No group telegrams of main groups 14 and 15 are routed to KNX/EIB.

Route: All group telegrams of the main groups 14 and 15 are routed to KNX/EIB.

Group telegrams (main groups 16 to 31):

Block: No group telegrams of these main groups are routed to KNX/EIB.

Route: An additional page appears on which the routing of main groups 16 to 31 can be disabled or enabled in pairs.

Physically addressed telegrams:

Block: No physically addressed telegrams are routed to KNX/EIB.

Route: All physically addressed telegrams are routed to KNX/EIB.

Filter: The physical address is used to check whether the received physically addressed telegram should be routed to KNX/EIB.

Broadcast telegrams:

Block: No received broadcast telegrams are routed to KNX/EIB.

Route: All received broadcast telegrams are routed to KNX/EIB.

KNX IP Router

Resending of group telegrams:

Disable: The received group telegram is not resent to KNX/EIB in case of a fault.

Enable: The received group telegram is resent up to three times in case of a fault.

Resending of physically addressed telegrams:

Disable: The received physically addressed telegram is not resent to KNX/EIB in case of a fault.

Enable: The received physically addressed telegram is resent up to three times in case of a fault.

Resending of broadcast telegrams:

Disable: The received broadcast telegram is not resent to KNX/EIB in case of a fault.

Enable: The received broadcast telegram is resent up to three times in case of a fault.

ETS Connection Manager

If the IP configuration of the KNX IP Router is valid, the router can be used as an interface to KNX/EIB.

The following configuration is necessary: Select the button Settings and the tab Communication in the main window of ETS4. All available connections are listed by Configured connections. Select the desired connection.

To be able to access KNX/EIB, the KNX IP Router requires a second physical address. This second physical address is only used for bus access and must be set up separately.

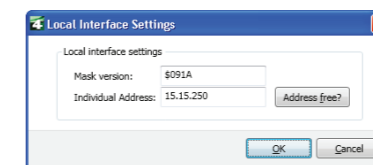

A dummy device may have to be added to the ETS project to reserve this address.

Installation and connection

The KNX IP Router is designed for installation in a rack with a depth of 2 units. It contains the following display and control elements:

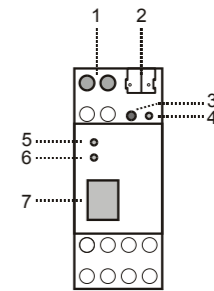

- 1: Connector for external power supply (12 V to 24 V AC/DC)
- 2: Connector for KNX/EIB with a bus terminal
- 3: Learn key
- 4: Learn LED (red)
- 5: LED (green):
- Lights up to indicate bus voltage on KNX/EIB
- Flashes to indicate telegram traffic
- 6: LED (green):
- Lights up to indicate an Ethernet connection
- Flashes to indicate telegram traffic
- 7: RJ 45 socket for connecting an Ethernet patch cable

An external power supply only needs to be connected if the switch in use does not support Power-over-Ethernet.

